

type number:

**DZZ\_ZM**

product description:

The hanger is designed for the fastening of the wire tray to a wall. It is designed for trays of dimensions 60X60 and 60X100.

Installation is carried out by inserting the longitudinal wires on the side of the cable tray into the prepared grooves of the hanger. To secure the wire tray, the hooks of the hanger are bent around the inserted wire.

The max. recommended load for one mounting point is 10 kg.

surface finish:

ZM - Magnelis® - galvanized steel with admixture of magnesium and aluminum according to EN 10346, EN 10143, protective layer 18-31 µm

meets the requirements: ČSN EN 61537:02

classification :

ČSN 73 0895P 90-R  
DIN 4102-12E 90  
STN 92 0205PS 90

Fire classification depends on the specific conditions of the cable tray, detailed in the catalog Systems with maintained functionality in fire.

storage:

ČSN EN 60721-3-1

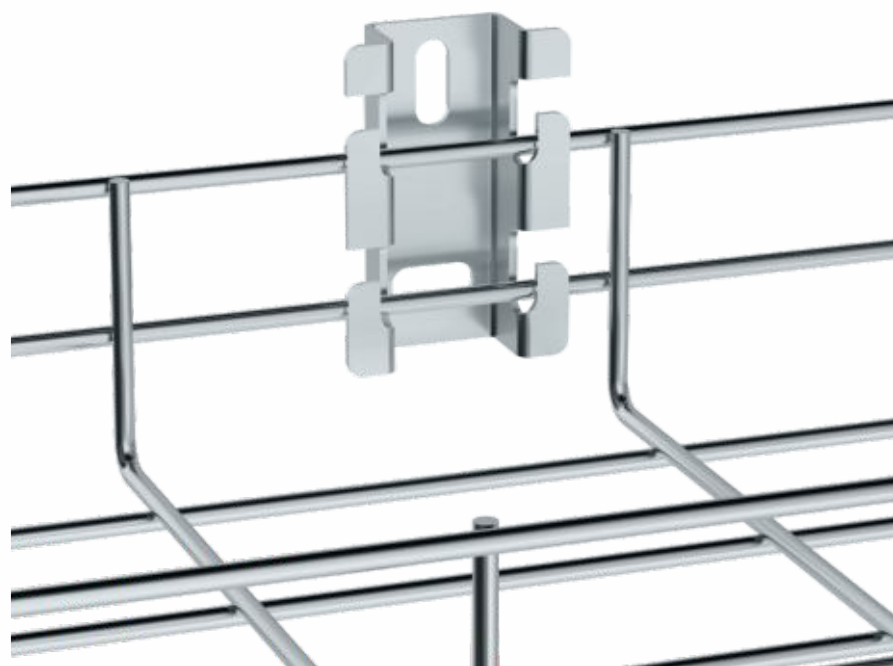
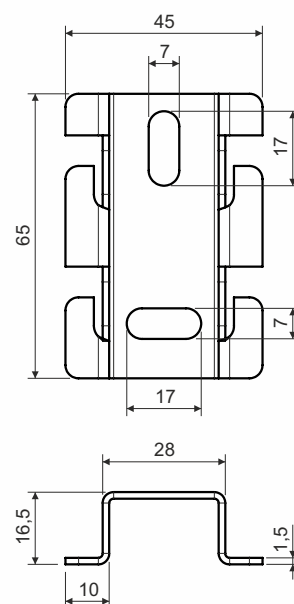

 **WARNING****Risk of injury from cutting**

Although the cable trays are produced with maximum effort to minimize sharper edges, it is necessary to wear protective gloves to carry, grip and work with cable elements.

**Electricity injury**

As individual components of cable management systems are made of electrical conductive material, it is essential not to work with a system near live electrical parts. Infringement of the safety regulations may cause serious injury of health or death.

**Safe Use**

Under normal and foreseeable conditions of use, there are no risks to consumers, provided that proper installation and usage are carried out in accordance with the installation manual.

recycling codes:



DZZ